



Newsletter

- New Product Information
 - New Design & Specification
 - Miscellaneous
- Verfügbar ab Oktober. 2007

SLEDGE HAMMER S50

NO. 6225- F
MTA4 Version2.0
1:8 Nitro Powered 4WD Monster Truck

599,- € UPE

Unleash The Power!
Pro-50BK (8.2cc) size engine



Technische Daten:

Länge:	615mm
Breite:	438mm
Höhe:	273mm
Radstand:	368mm
Gewicht:	6200g
Bodenfreiheit:	108mm



Bilder von Prototypenmodellen. Änderung in Ausführung und Farbgestaltung vorbehalten.

Subject	6225-F MTA4 S50 Sledge Hammer Launch	Ref No.	2007C012
---------	--------------------------------------	---------	----------



Newsletter

- New Product Information
 - New Design & Specification
 - Miscellaneous
- Verfügbar ab Oktober 2007

SLEDGE HAMMER S50

NO. 6225- F

MTA4 Version 2.0

1:8 Nitro Powered 4WD Monster Truck

Features:

Der MTA-4 SLEDGE HAMMER S50 zerschmettert all seine Rivalen. Man nehme den legendären MTA4 Truck und kombiniere ihn mit dem neuen bärenstarken PRO50-BK 8,2ccm Motor und man erhält die fieseste Höllenmaschine auf dem Monstermarkt!.

Um sicher gehen zu können, die geballte Kraft dieses Aggregates auf den Boden zu bekommen sind alle Zahnräder im bewährten Zweiganggetriebe aus gehärtetem Stahl ausgeführt. Die neuen gehärteten Stahl CVA's leiten das enorme Drehmoment perfekt an die neuen Chromspeichenfelgen mit neuen Super Grip Reifen weiter.

- Neuer überdimensionaler Motorkühlkopf
- Neue Slipperkupplung und gehärtete Stahlzahnräder im Getriebe
- Neues ultrahartes Stahlhauptzahnrad
- Neue „heavy duty“ CVA's
- Neues High Performance Heckauslassresonanzrohr
- Neue härtere Dämpferfedern
- Neuer PRO50-BK 8,2ccm MegaPower Motor
- Neue Karosserie mit neuem Design
- Neue Chromspeichenfelgen mit neuen Super Grip Reifen
- Neuer stoßabsorbierender Frontrammer
- Neuer hinterer Wheelie Bar

MONSTER
SPEED



Reverse Module Included



Subject 6225-F MTA4 S50 Sledge Hammer Launch

Ref No. 2007C012







Newsletter

- New Product Information
- New Design & Specification
- Miscellaneous

Verfügbar ab Oktober 2007

NO. 6225- F SLEDGE HAMMER S50 1:8 Nitro Powered 4WD Monster Truck

Item No	Body Style	Rx/ Tx	Electronic	Accessory	MTA-S50
W/PRO-50BK Hex-Shaft Start Engine					
6225-FC1	RED	P3(40)	BQ303-40+BQ2132x2+BQ2135	None	BQ2132 =ACE R/C S1903 STD SERVO
6225-FC2	BLUE	P3(40)	BQ303-40+BQ2132x2+BQ2135	None	BQ2135 =ACE R/C S1903 METAL GEAR SERVO
   					
No.6525-F*1 SLEDGE HAMMER S50 (Rot)		No.6525-F*2 SLEDGE HAMMER S50 (Blau)			

Subject	6225-F MTA4 S50 Sledge Hammer Launch	Ref No.	2007C012
---------	--------------------------------------	---------	----------



Newsletter

- New Product Information
- New Design & Specification
- Miscellaneous

Verfügbar ab Oktober 2007

SLEDGE HAMMER S50



NO. 6225- F MTA4 Version 2.0
1:8 Nitro Powered
4WD Monster Truck



Neue überdimensionale ChromSpeichenfelgen mit Super Grip Reifen.



8.2cc
Massive Block
 8,2ccm Thunder Tiger Pro50-BK Monster Power Motor mit bequemem Sechskantstarter

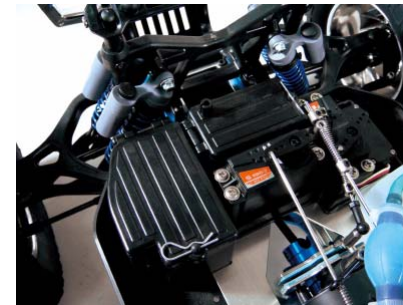

Spritzwasser geschützte RC-Box

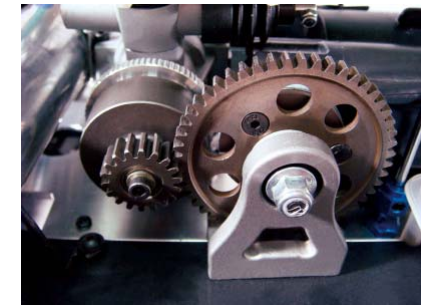

Neue Kupplungsglocke, gehärtetes Stahlhauptzahnrag und Stahl Getrieberäder



Neuer Stoßabsorbierender Frontrammer

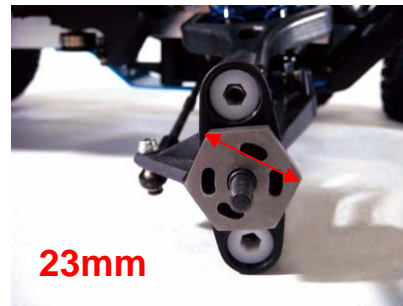

23mm
 Heavy-duty 23mm Aluminium Radmitnehmer



Neuer Wheelie Bar



New MTA S50 **MTA S28**
 Air Filter Air Filter

Neuer 2 Stage Luftfilter

Subject	6225-F MTA4 S50 Sledge Hammer Launch	Ref No.	2007C012
---------	--------------------------------------	---------	----------



Newsletter

- New Product Information
- New Design & Specification
- Miscellaneous

Verfügbar ab Oktober 2007

SLEDGE HAMMER S50



NO. 6225- F MTA4 Version 2.0
1:8 Nitro Powered
4WD Monster Truck

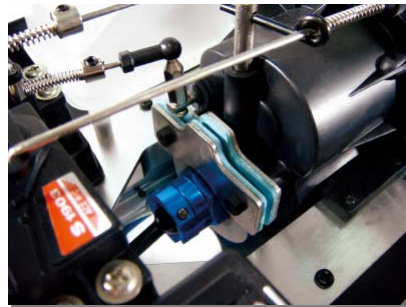

Massive Single Disk Bremse
für fadingfreies Bremsen



High Performance
Heckauslaß Resonanzrohr

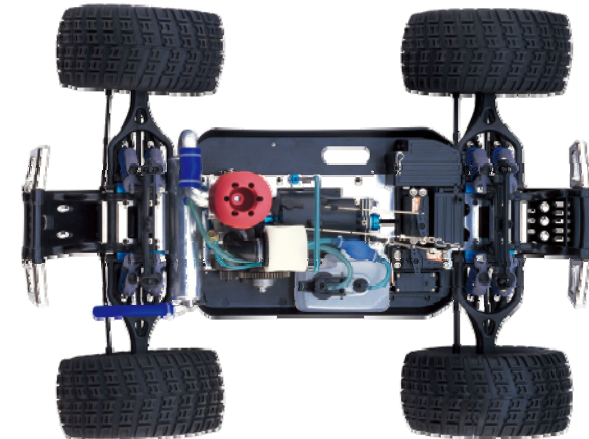

Subject 6225-F MTA4 S50 Sledge Hammer Launch

Ref No. 2007C012